

- ① FONDO
- ② FIANCO SINISTRO
- ③ FIANCO DESTRO
- ④ CATENA
- ⑤ FRONTALINO

### ASSEMBLAGGIO

*Il tempo di indurimento e la velocità di presa vengono influenzate dalla temperatura, dall'umidità, dalla porosità del materiale e dalla quantità di prodotto utilizzato.*

*I migliori risultati si ottengono se le temperature di prodotto, di superficie su cui applicare la Colla vinilica per legno e dell'ambiente è di circa 18-20° C. L'umidità ottimale del legno, invece dovrebbe essere del 8-12%.*

*La Colla vinilica per legno teme il gelo: per questo motivo non va usata al di sotto di 6/10°C e tutti gli incollaggi fatti a temperature inferiori ai 15°C possono risultare difettosi*



COLLA VINILICA

**Distribuire la colla nei fori diametro 8mm  
Assemblare i perni torniti**

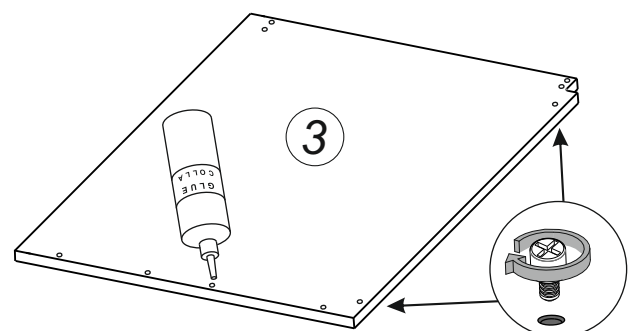
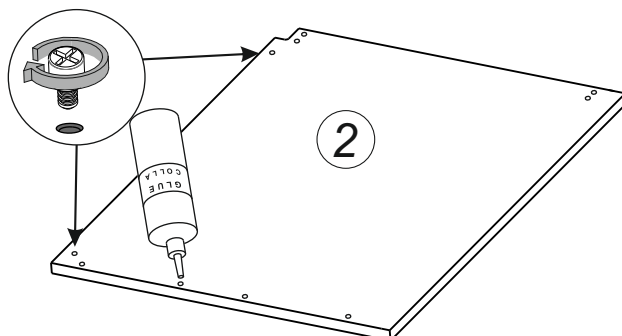

\* Per base forno L= 900mm passare a pagina 4

\* \* Per base forno ribassata H= 600mm passare a pagina 5

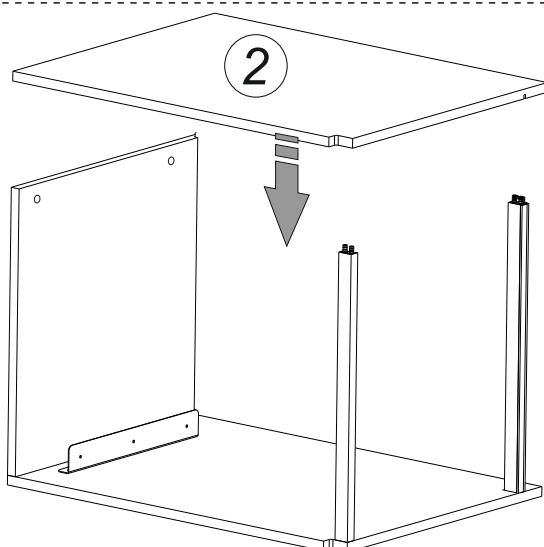
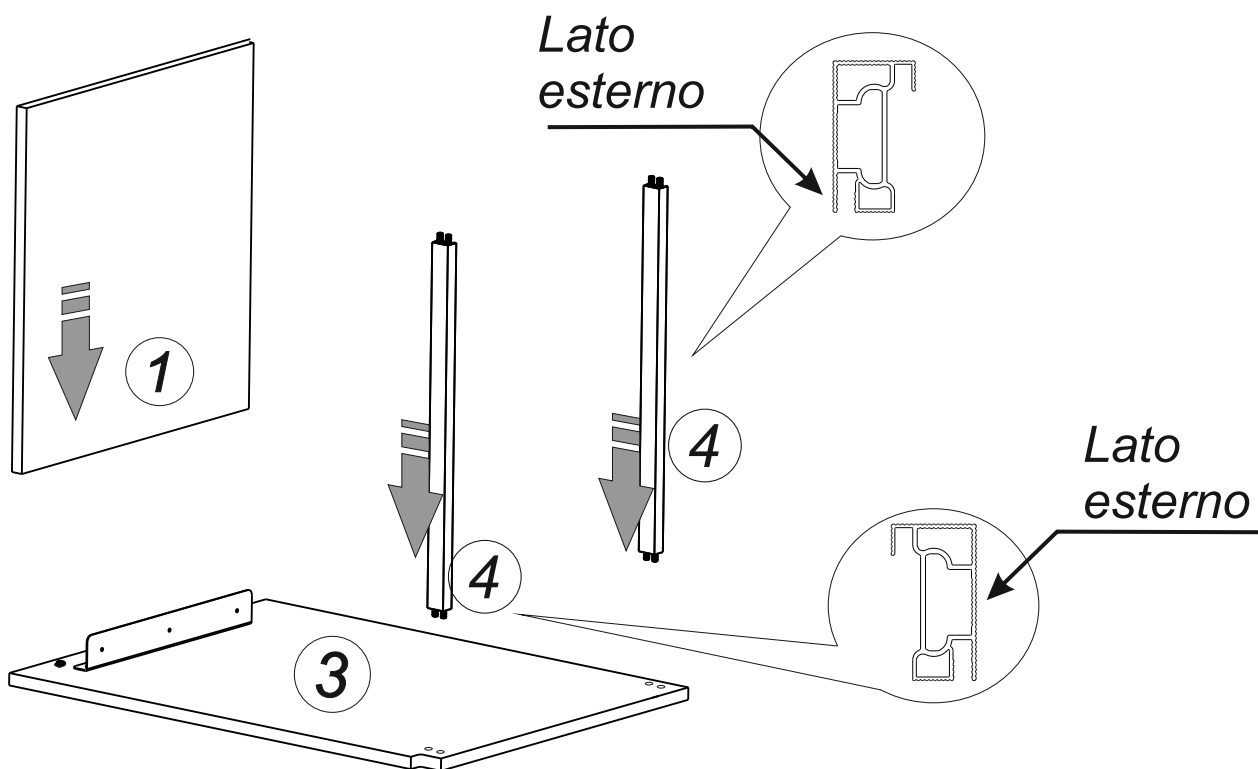
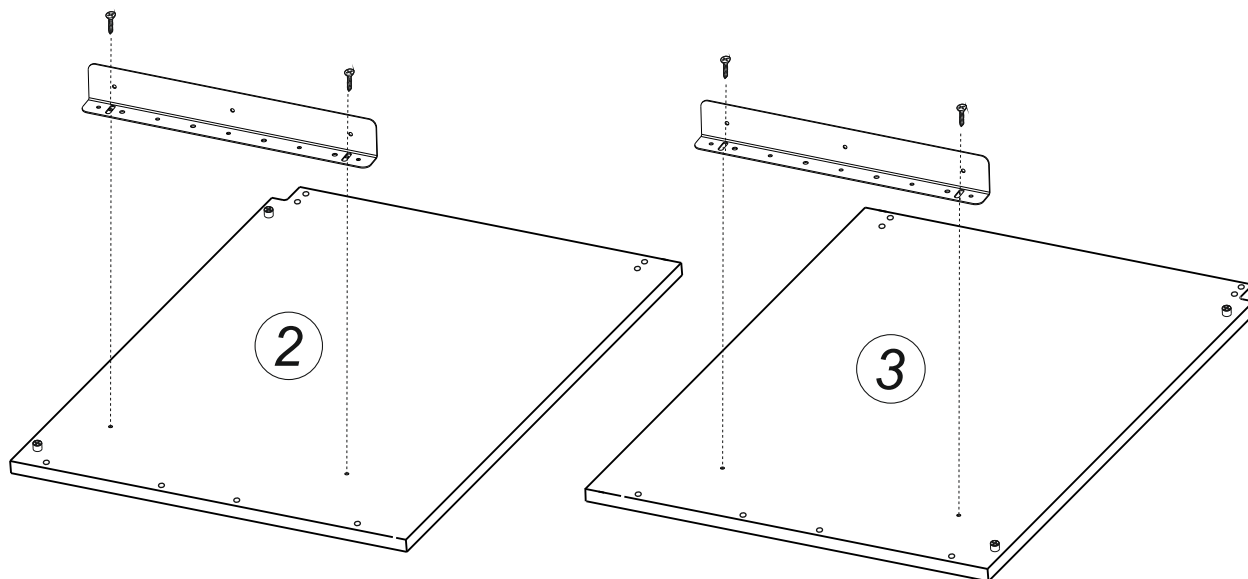

Chiudere i fianchi utilizzando dei morsetti di lunghezza adeguata.  
Frapporre del tessuto tra il morsetto e il mobile per proteggere le superfici di contatto da eventuali abrasioni accidentali dovute al serraggio del morsetto

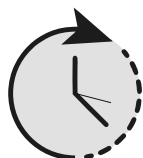
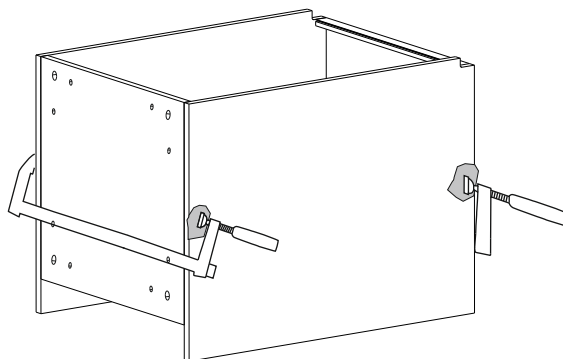

Chiusura morsetti minimo 30 minuti con temperatura di 20°C  
Aumentare il tempo se la temperatura dell'ambiente è inferiore

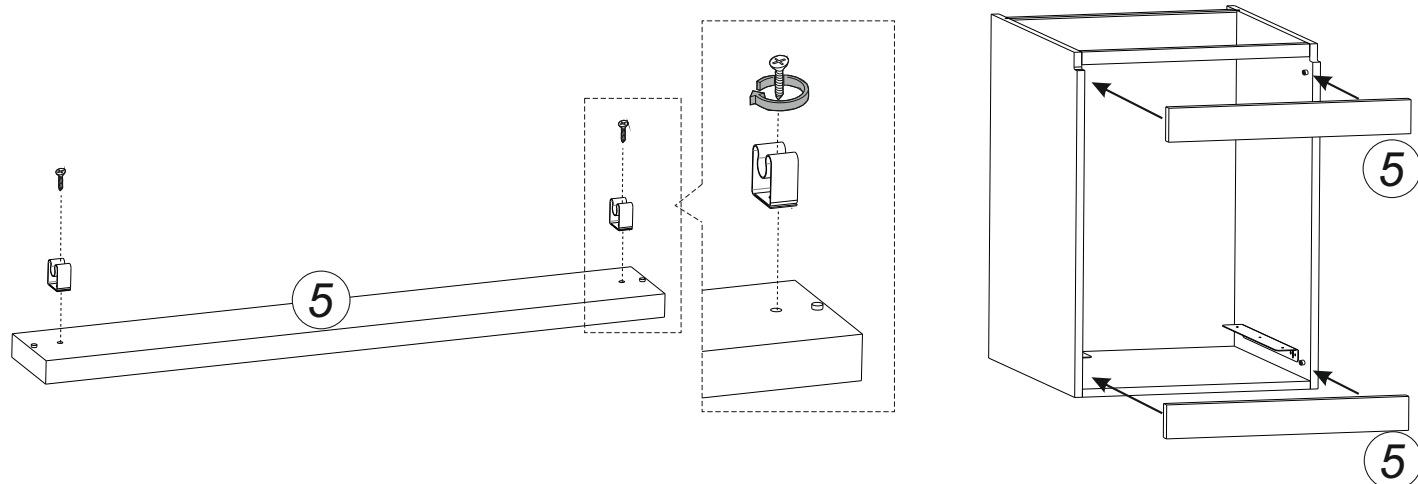
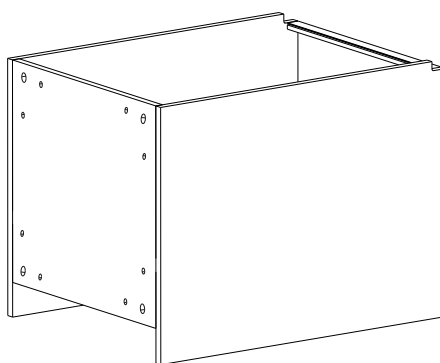
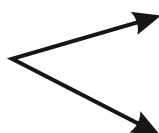
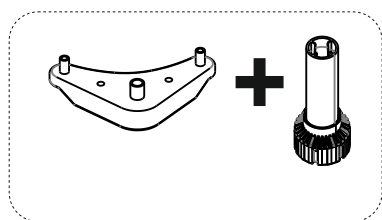

Per unione delle basi  
vedere foglio istruzione  
19900068  
(Usa il qr code a pag..1  
per accedere all'archivio)



Per assemblaggio  
dell'elettrodomestico  
seguire scrupolosamente  
le istruzioni del produttore  
del forno

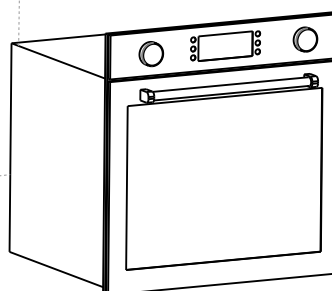
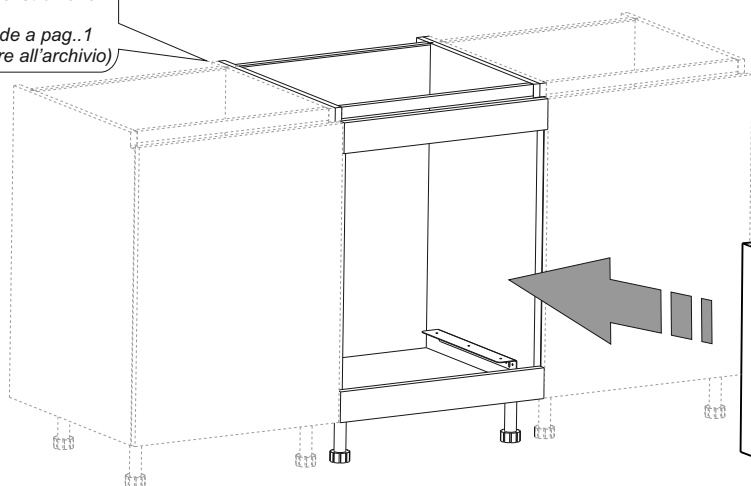

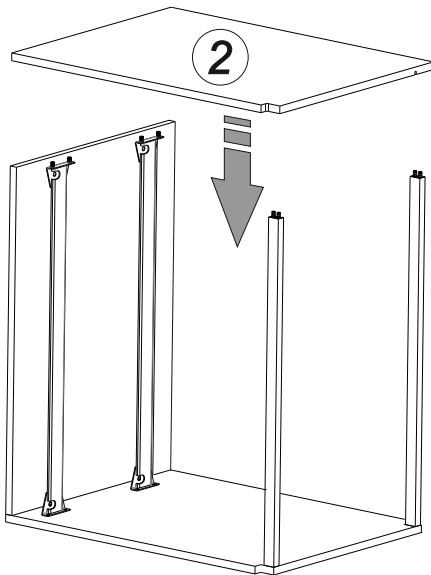
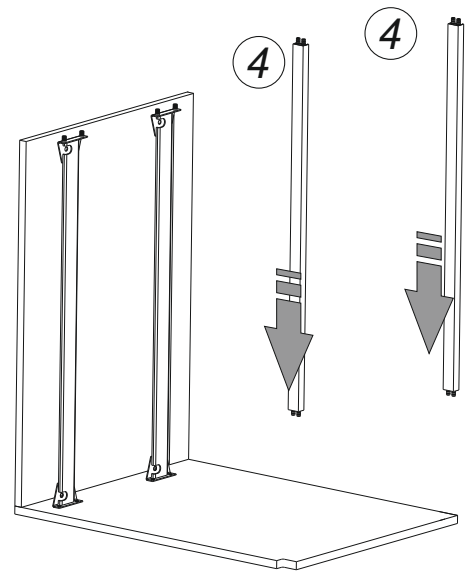
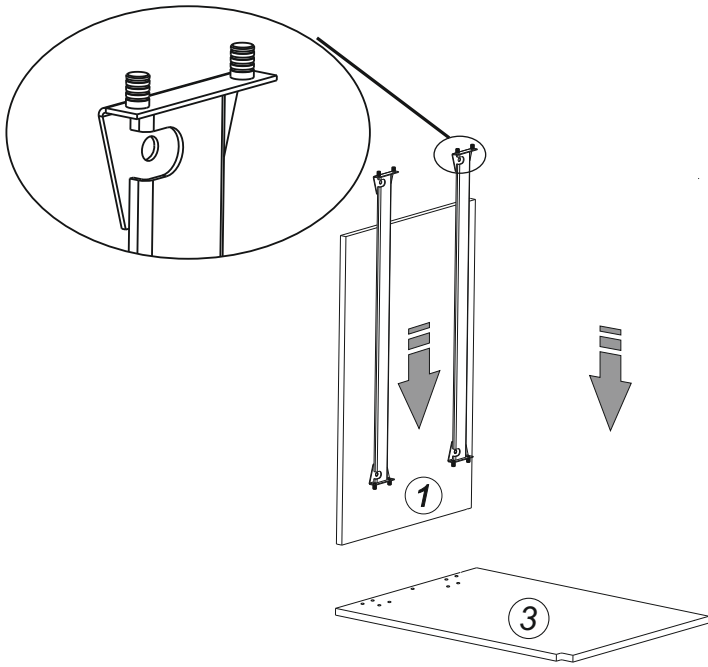

Chiudere i fianchi utilizzando dei morsetti di lunghezza adeguata.  
Frapporre del tessuto tra il morsetto e il mobile per proteggere le superfici di contatto da eventuali abrasioni accidentali dovute al serraggio del morsetto

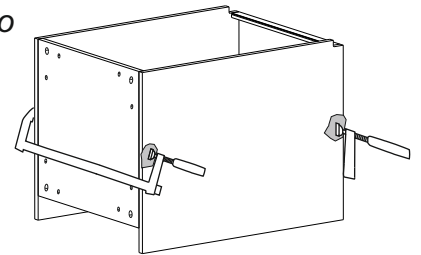

Chiusura morsetti minimo 30 minuti con temperatura di 20°C  
Aumentare il tempo se la temperatura dell'ambiente è inferiore

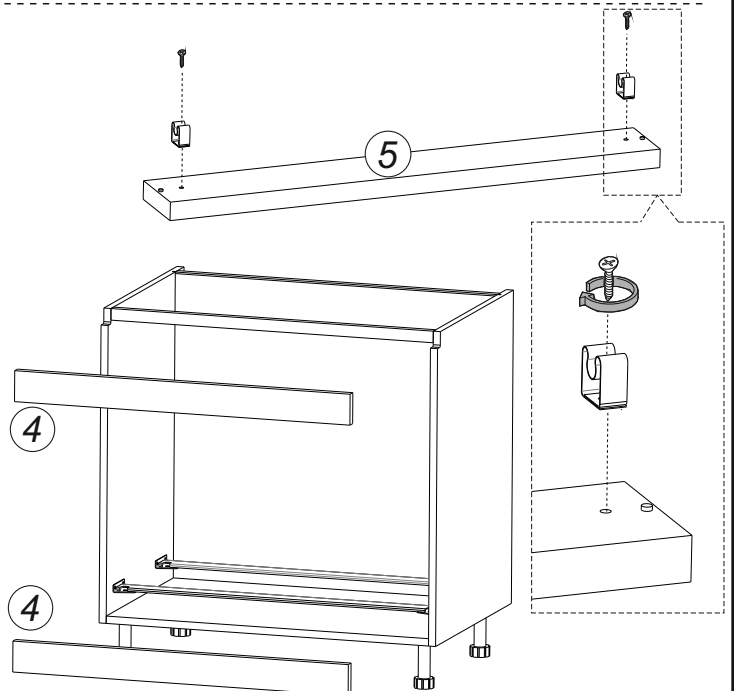
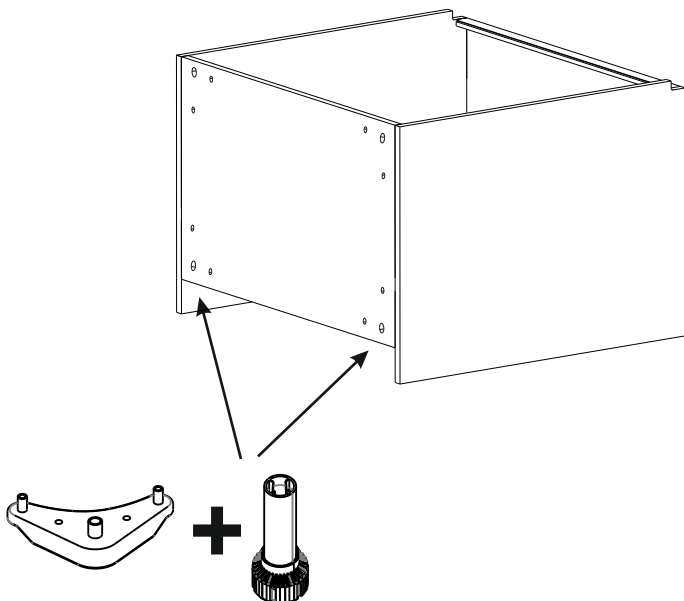

\*\*

BASE FORNO RIBASSATA

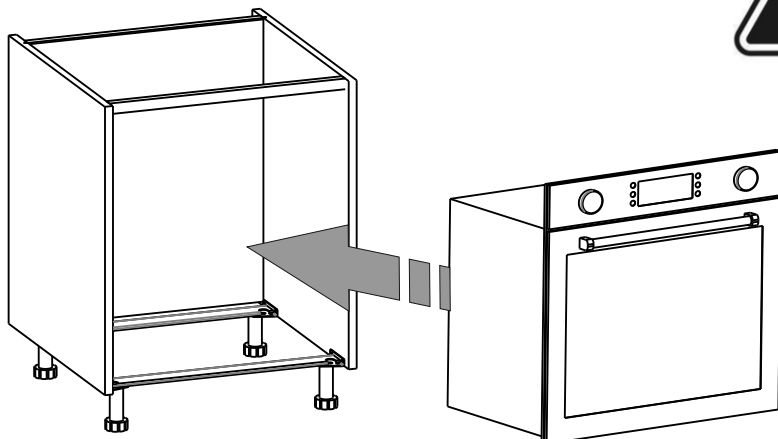
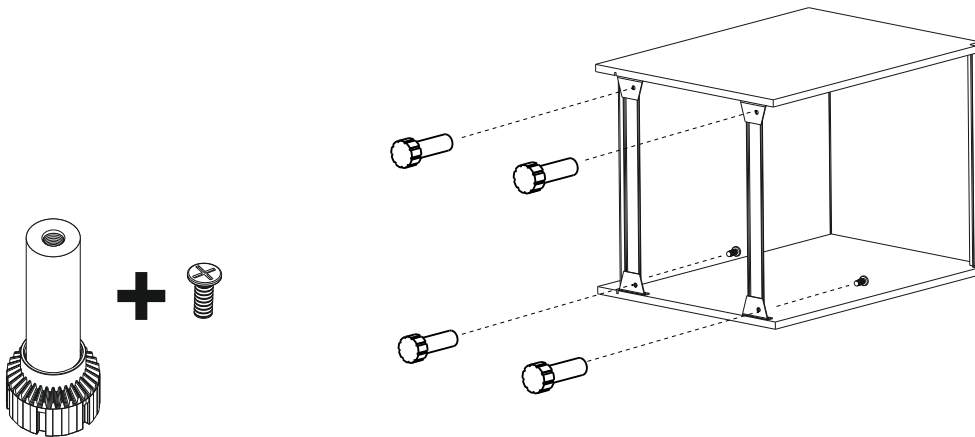
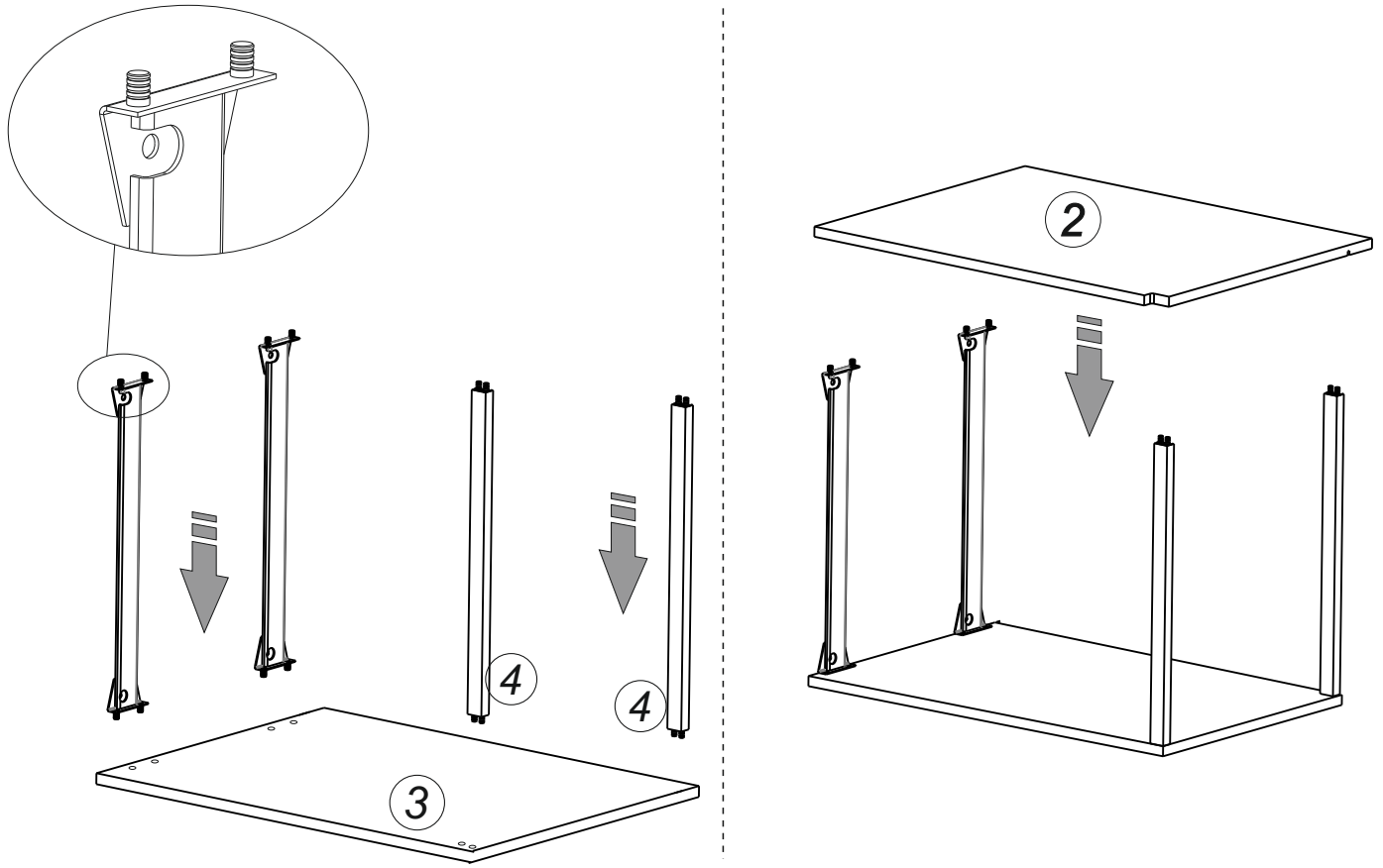

*Per assemblaggio dell'elettrodomestico seguire scrupolosamente le istruzioni del produttore del forno*