

- ① FONDO
- ② FIANCO SINISTRO
- ③ FIANCO DESTRO
- ④ SCHIENA
- ⑤ COPERCHIO
- ⑥ ANTA



COLLA
VINILICA

Il tempo di indurimento e la velocità di presa vengono influenzate dalla temperatura, dall'umidità, dalla porosità del materiale e dalla quantità di prodotto utilizzato.

I migliori risultati si ottengono se le temperature di prodotto, di superficie su cui applicare la Colla vinilica per legno e dell'ambiente è di circa 18-20° C. L'umidità ottimale del legno, invece dovrebbe essere del 8-12%.

La Colla vinilica per legno teme il gelo: per questo motivo non va usata al di sotto di 6/10°C e tutti gli incollaggi fatti a temperature inferiori ai 15°C possono risultare difettosi

ASSEMBLAGGIO

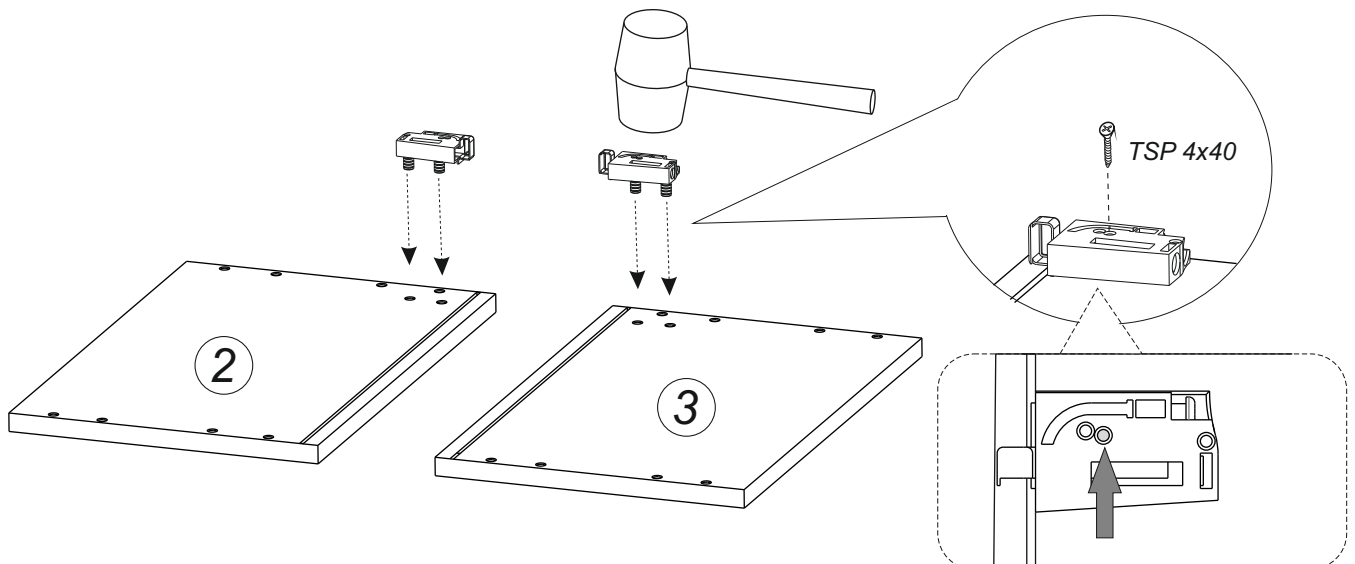

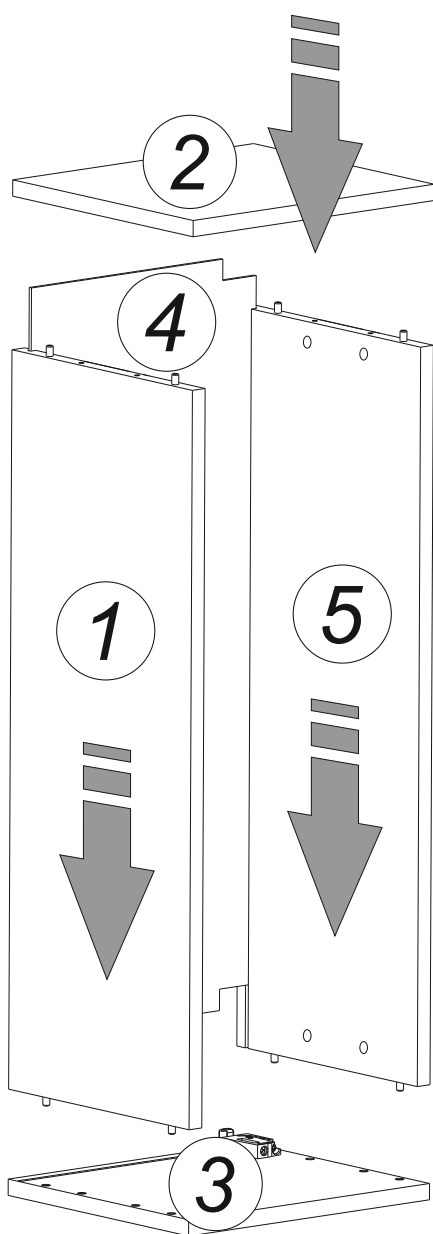
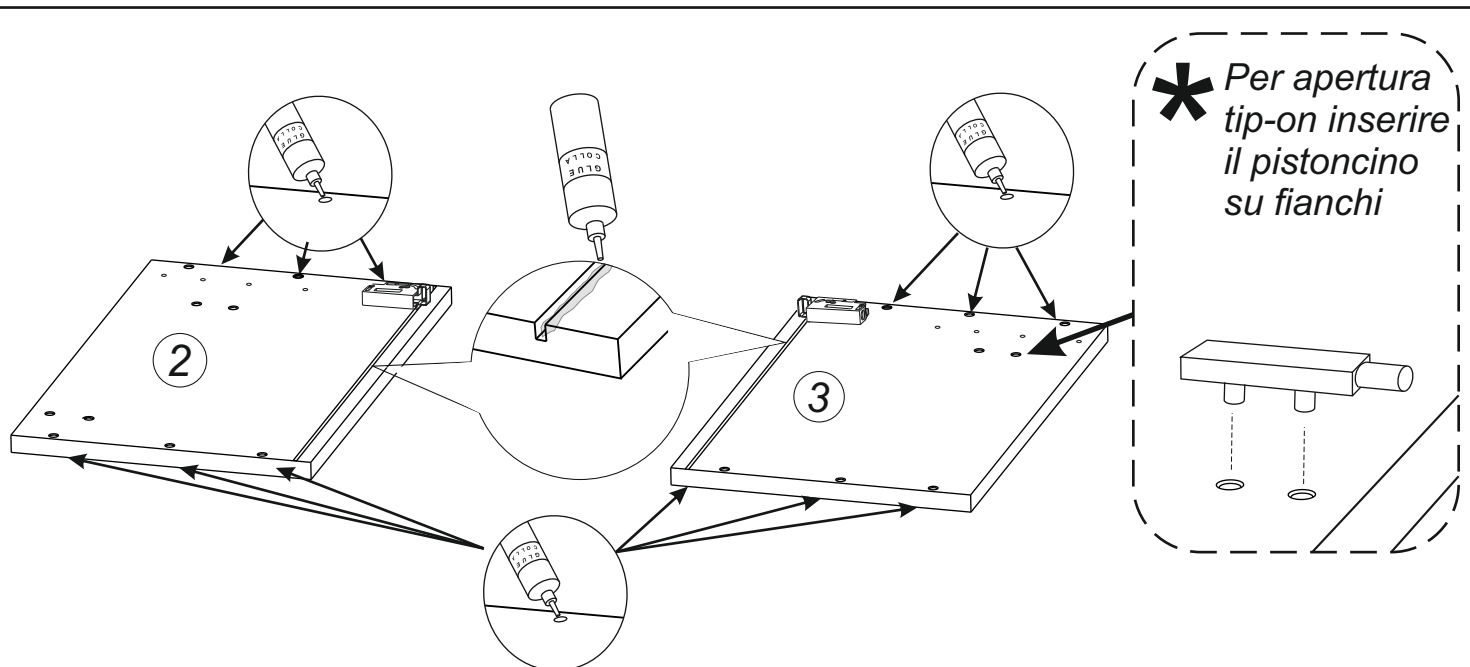

Chiudere i fianchi utilizzando dei morsetti di lunghezza adeguata.
 Frapporre del tessuto tra il morsetto e il mobile per proteggere le superfici di contatto da eventuali abrasioni accidentali dovute al serraggio del morsetto

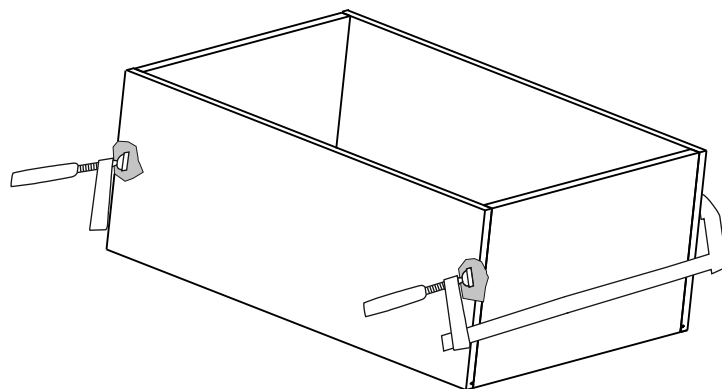

Chiusura morsetti
 minimo 30 minuti
 con temperatura di 20°C
 Aumentare il tempo
 se la temperatura
 dell'ambiente è inferiore

SISTEMA HK S

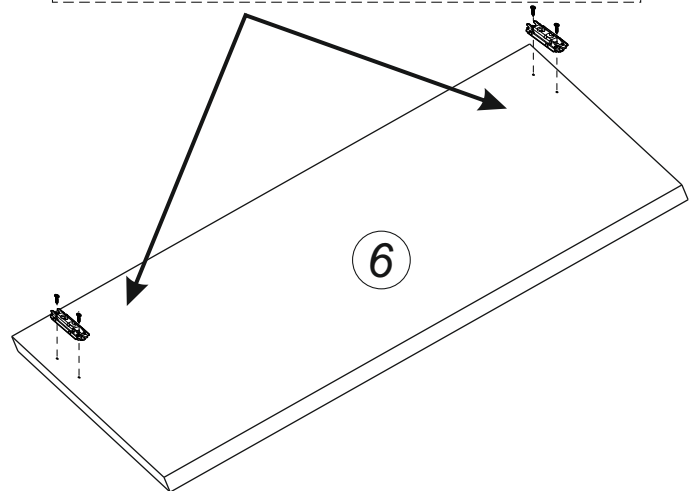
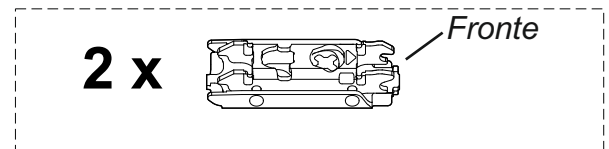
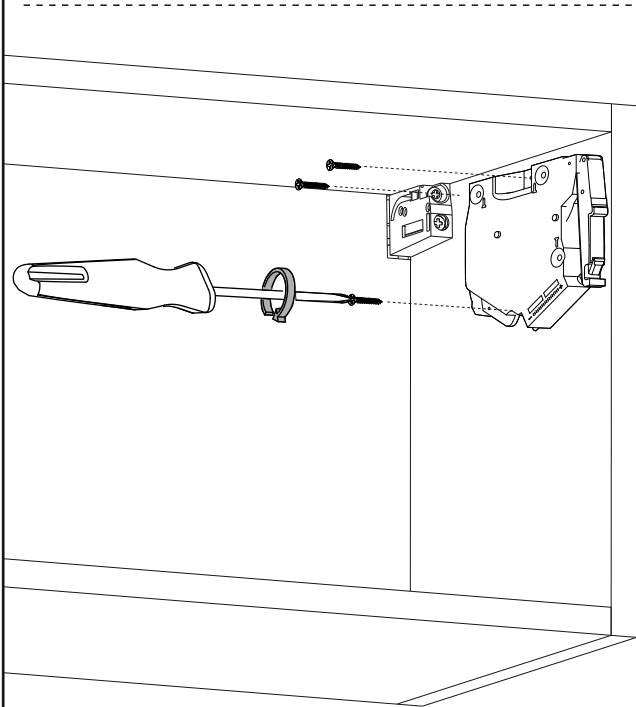
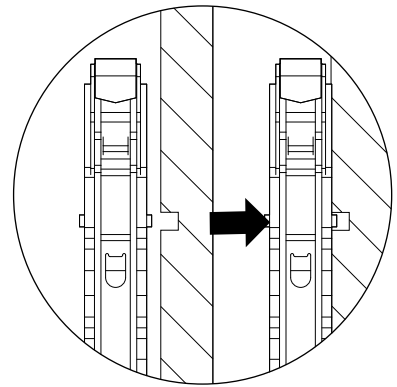
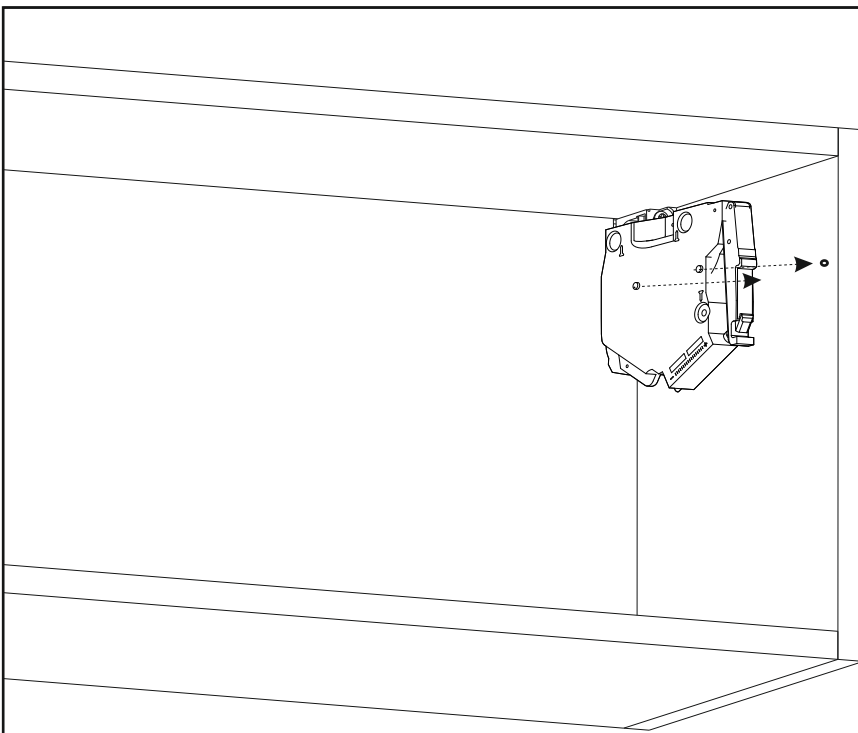

Pericolo di lesioni a causa del possibile scatto della leva verso l'alto !

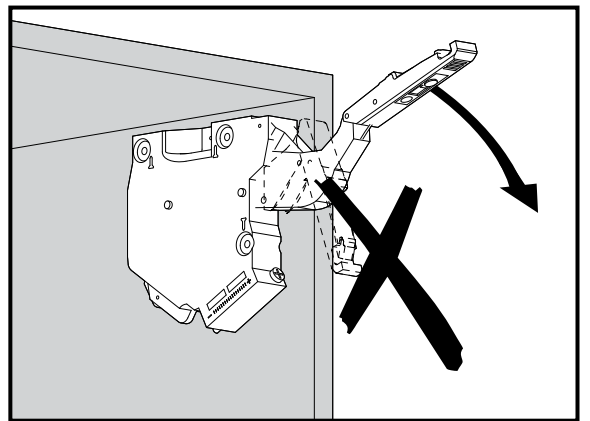

Non spingere la leva verso il basso dopo averla sollevata

SISTEMA HK S

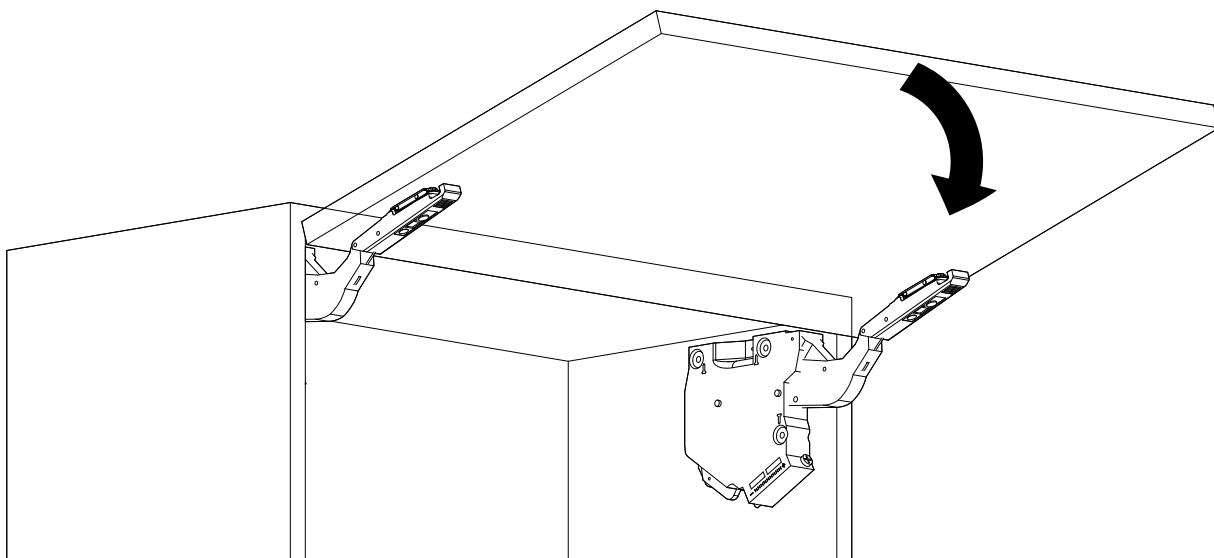
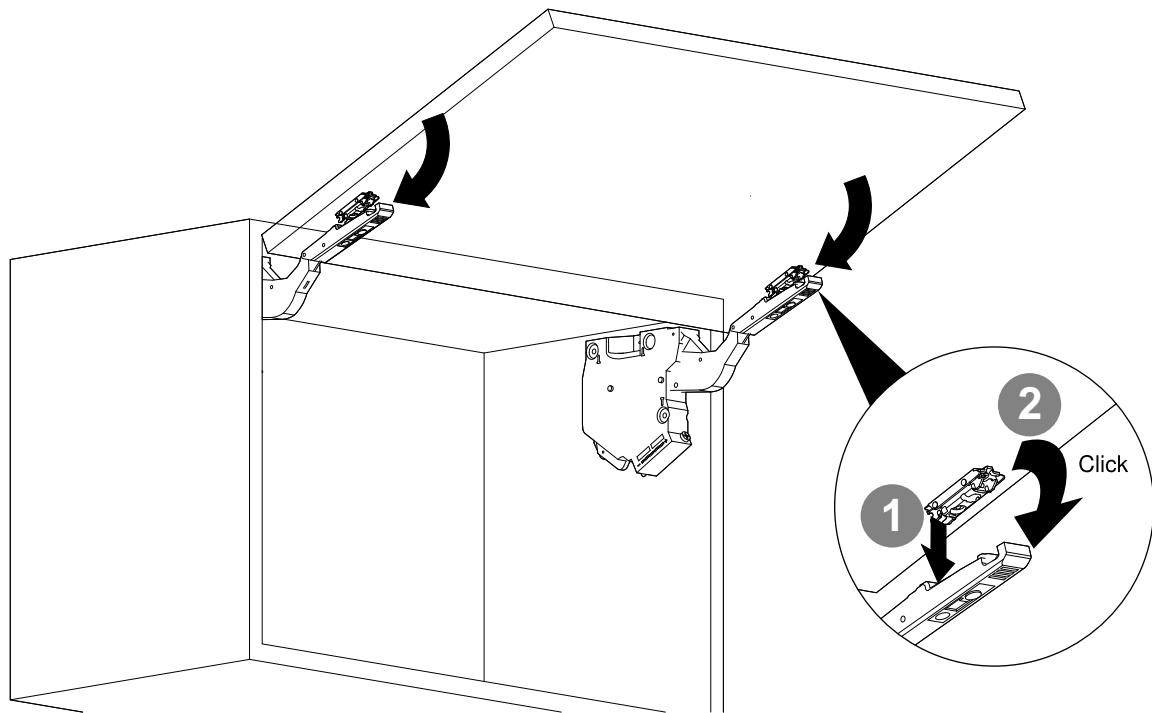
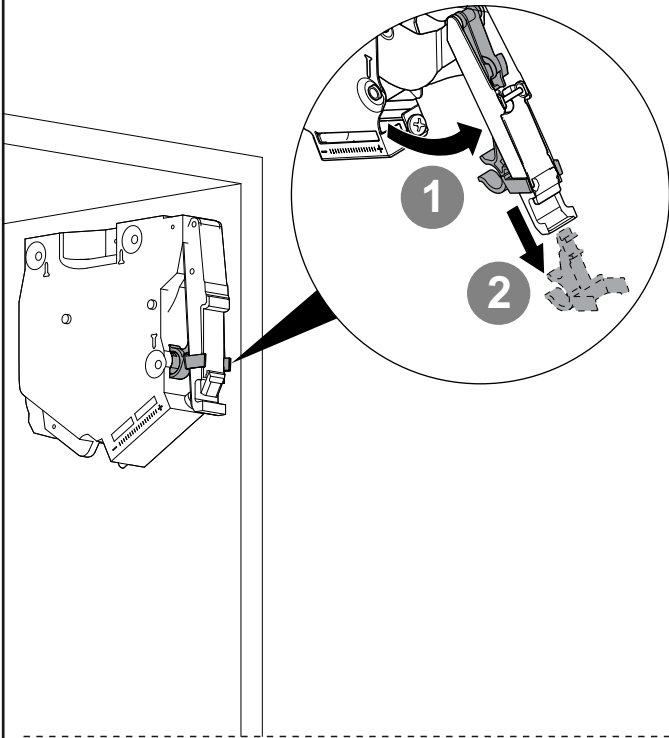

SISTEMA HK S

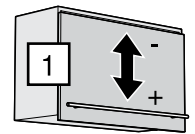
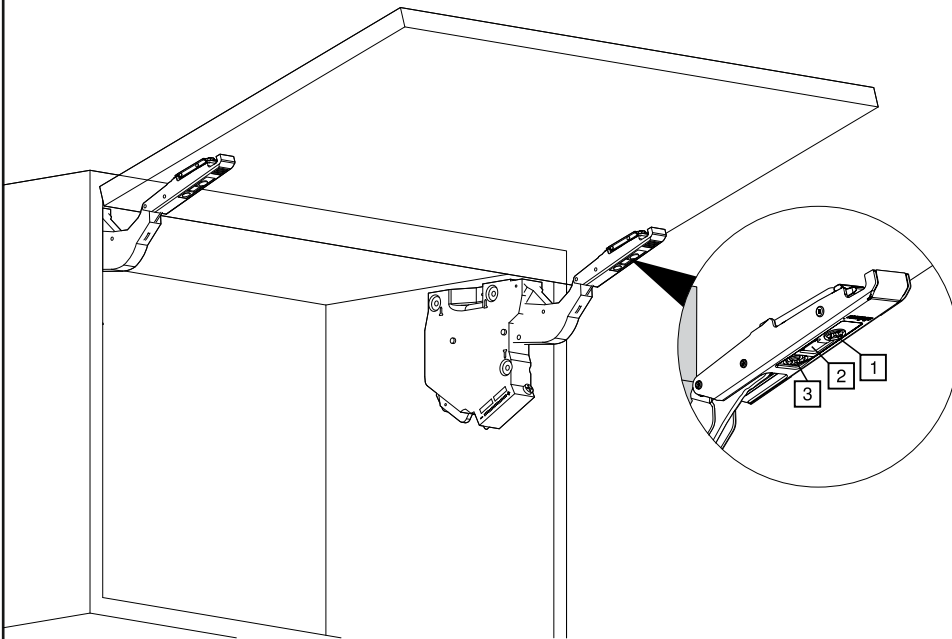
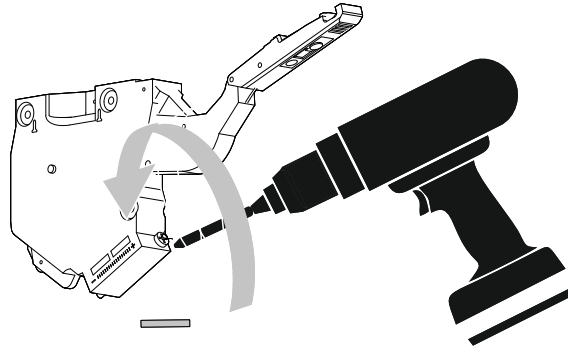
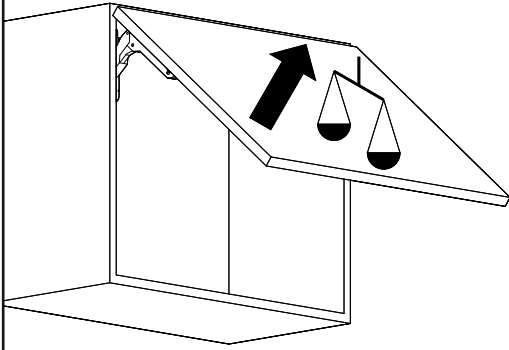
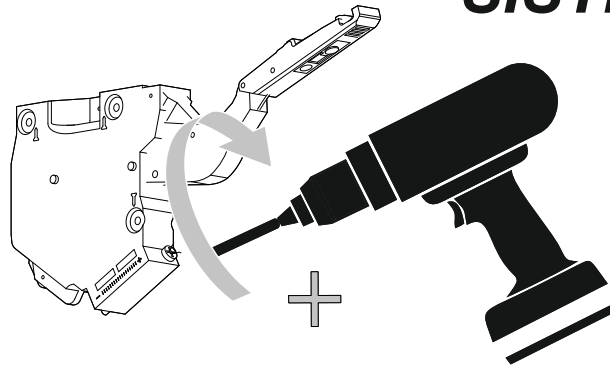
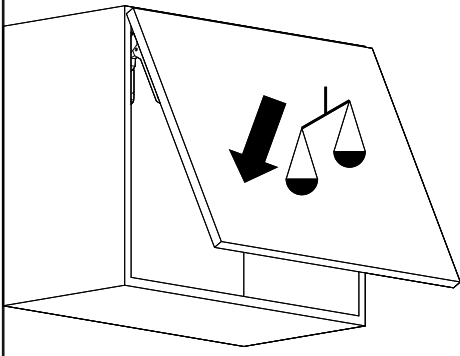

± 2

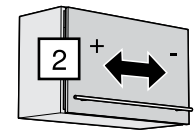

± 2

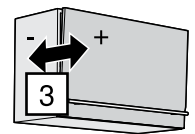

± 2

ASSEMBLAGGIO LIMITATORI DI APERTURA

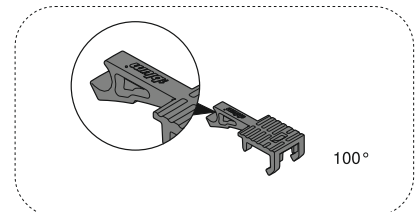
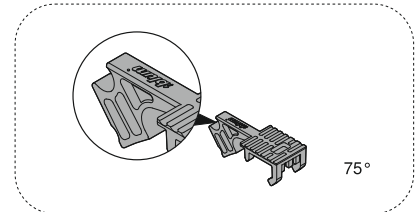
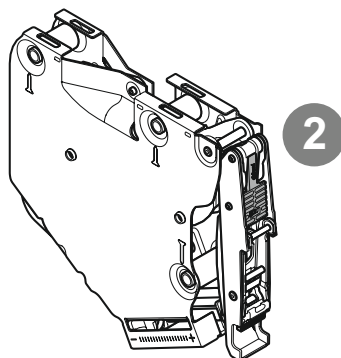
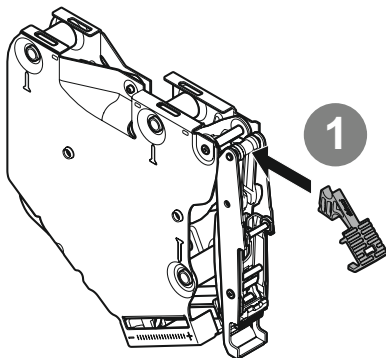

SISTEMA HK TOP

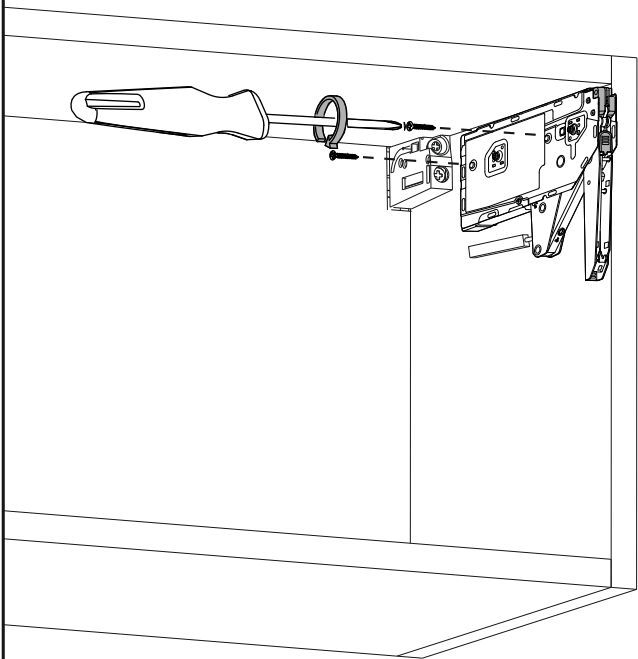
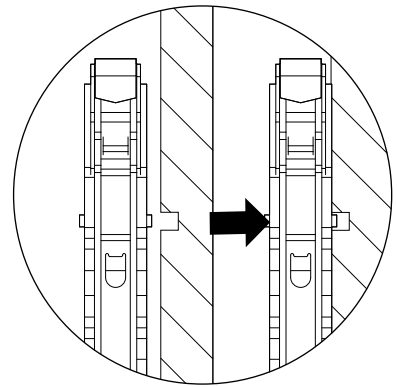
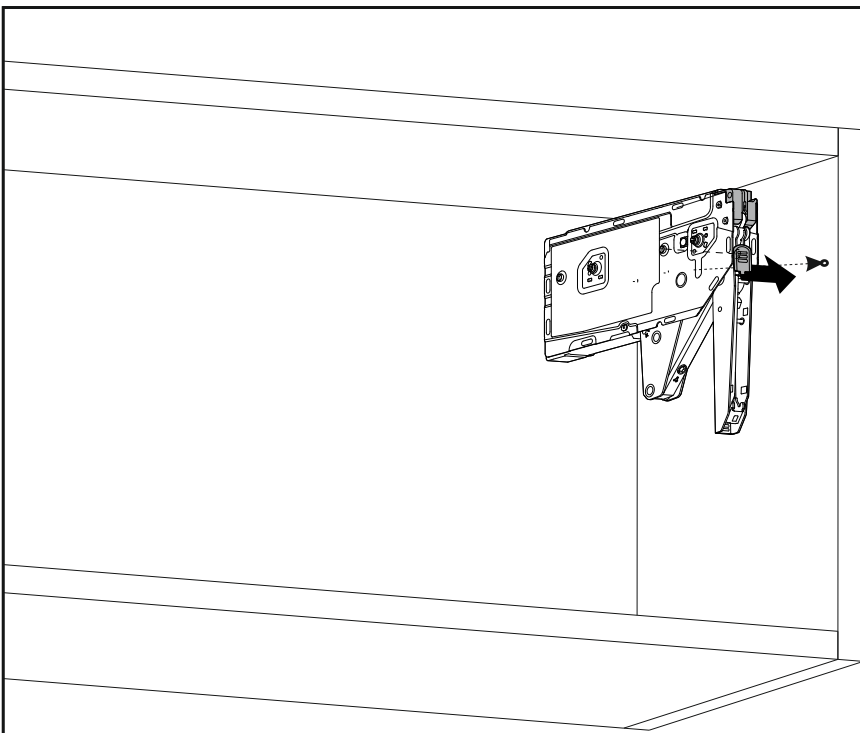

2 x

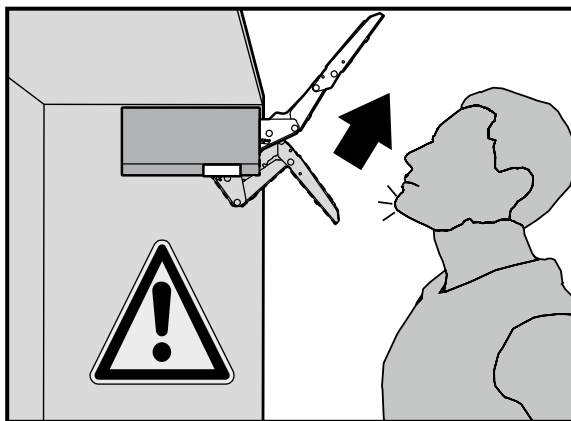
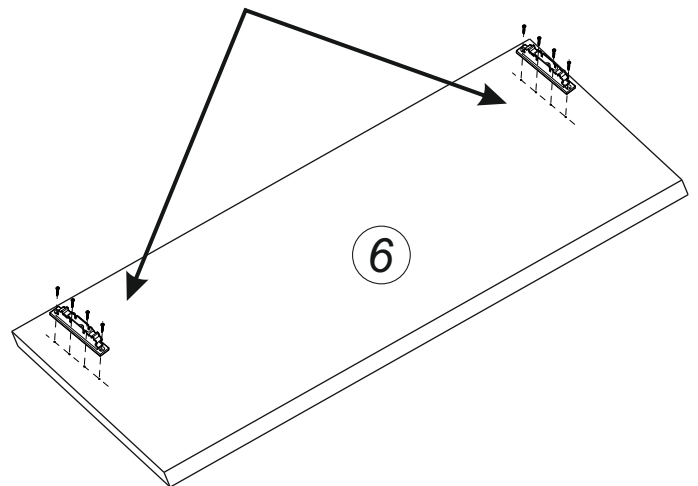
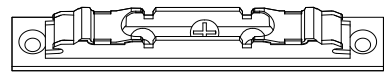

Pericolo di lesioni a causa del possibile scatto della leva verso l'alto !

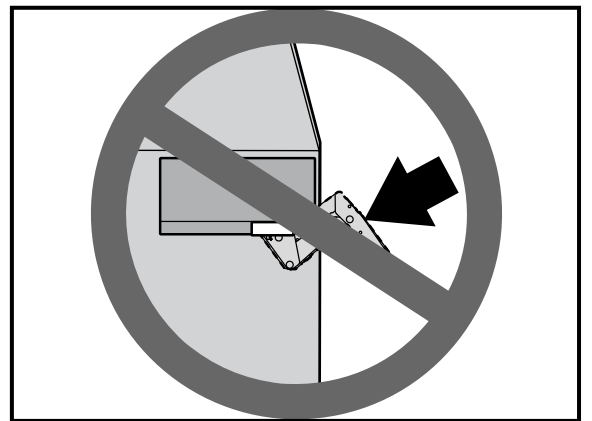

Non spingere la leva verso il basso dopo averla sollevata

SISTEMA HK TOP

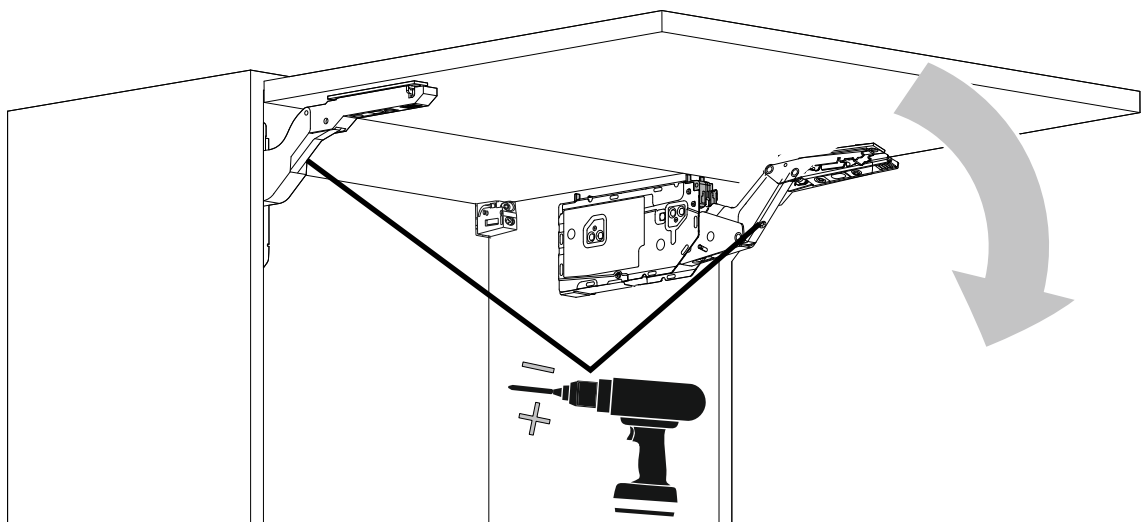
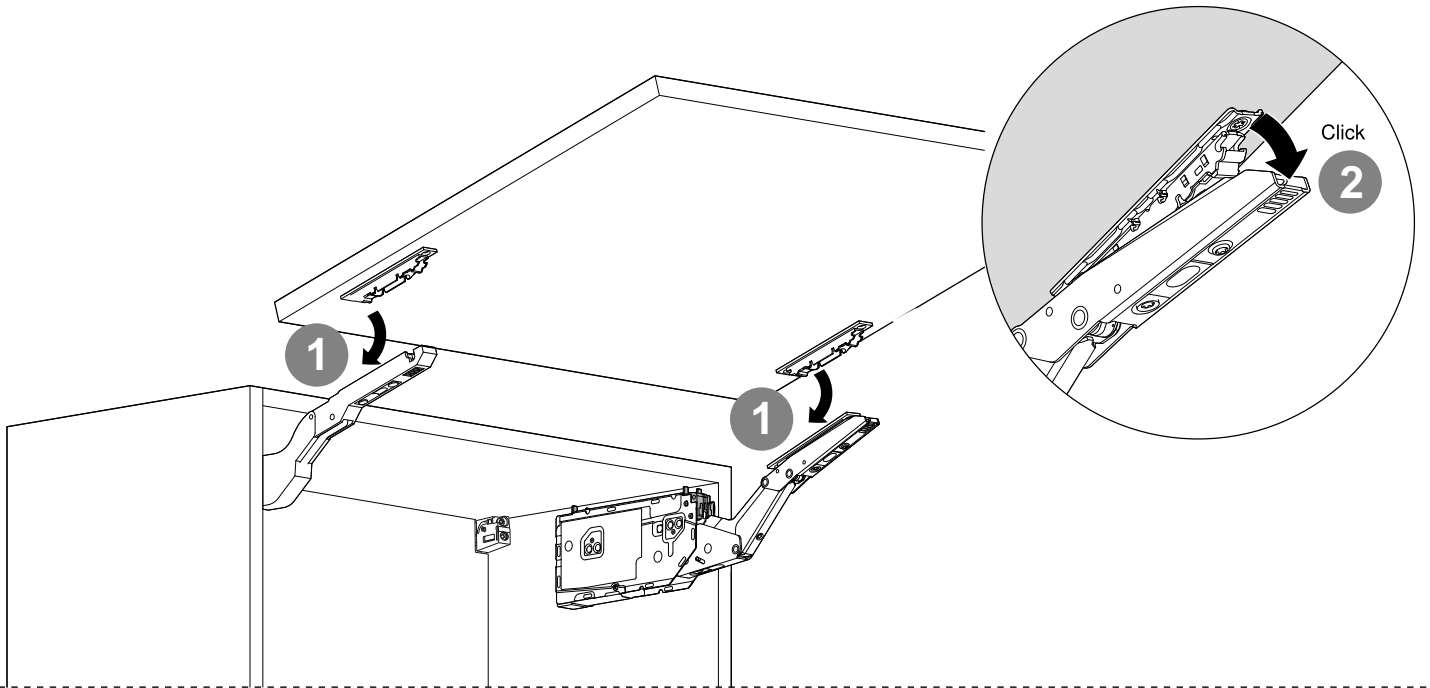
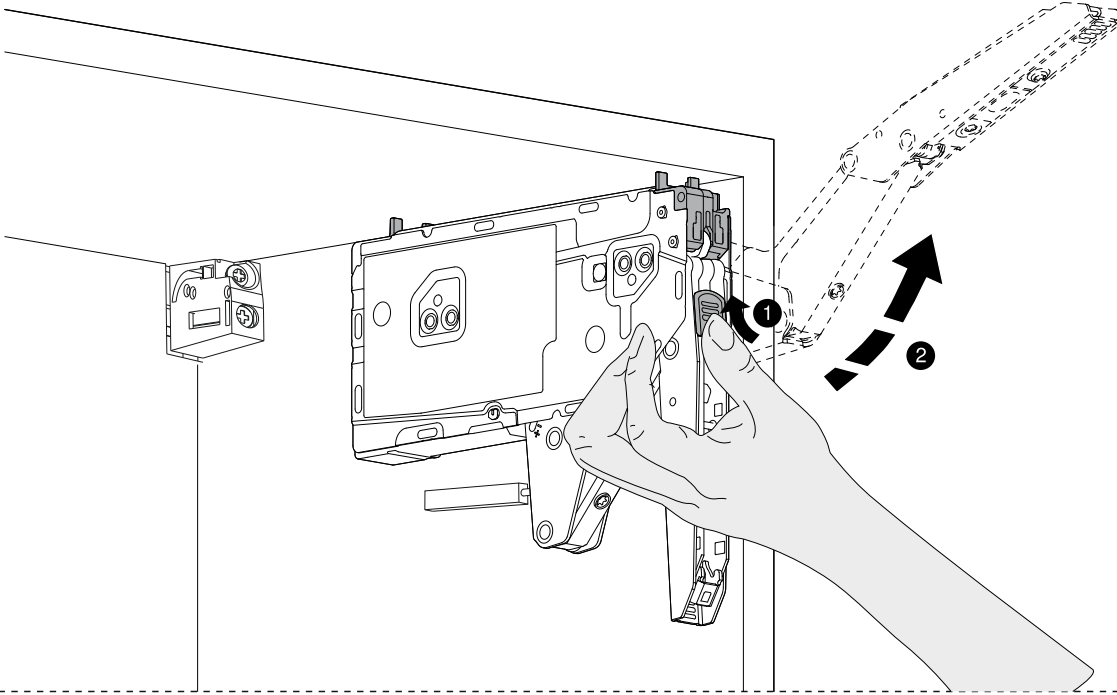

SISTEMA HK TOP

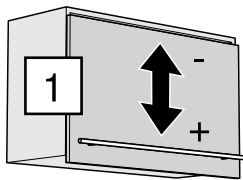
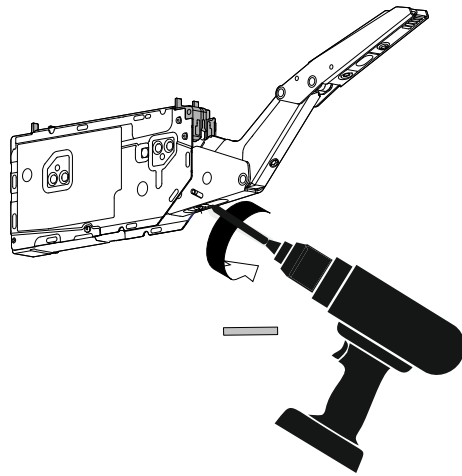
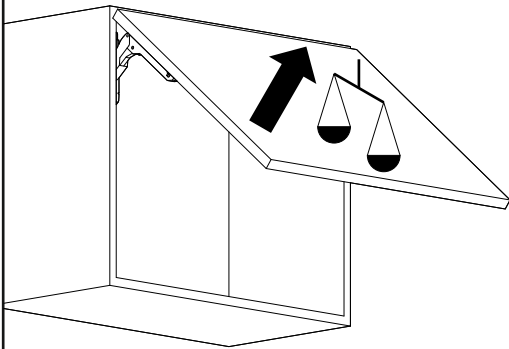
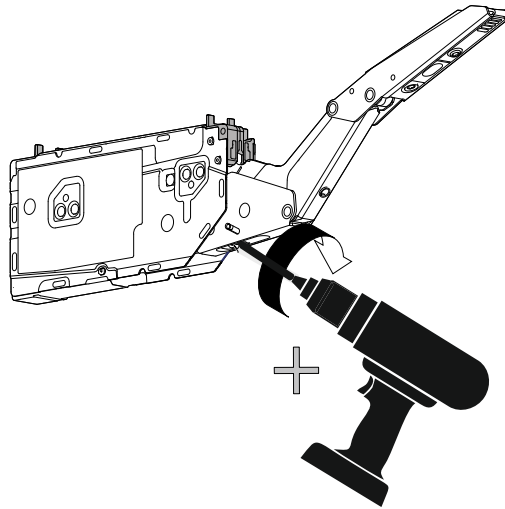
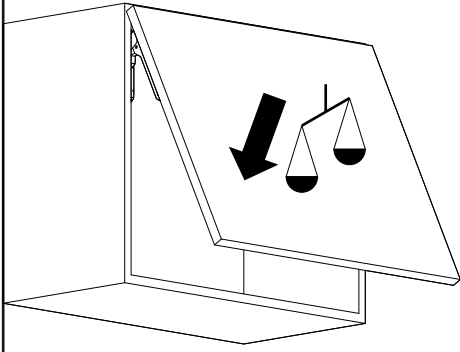

± 2

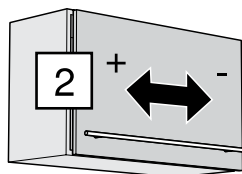

± 2

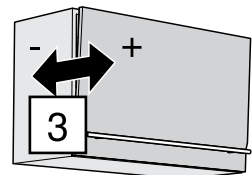

± 2

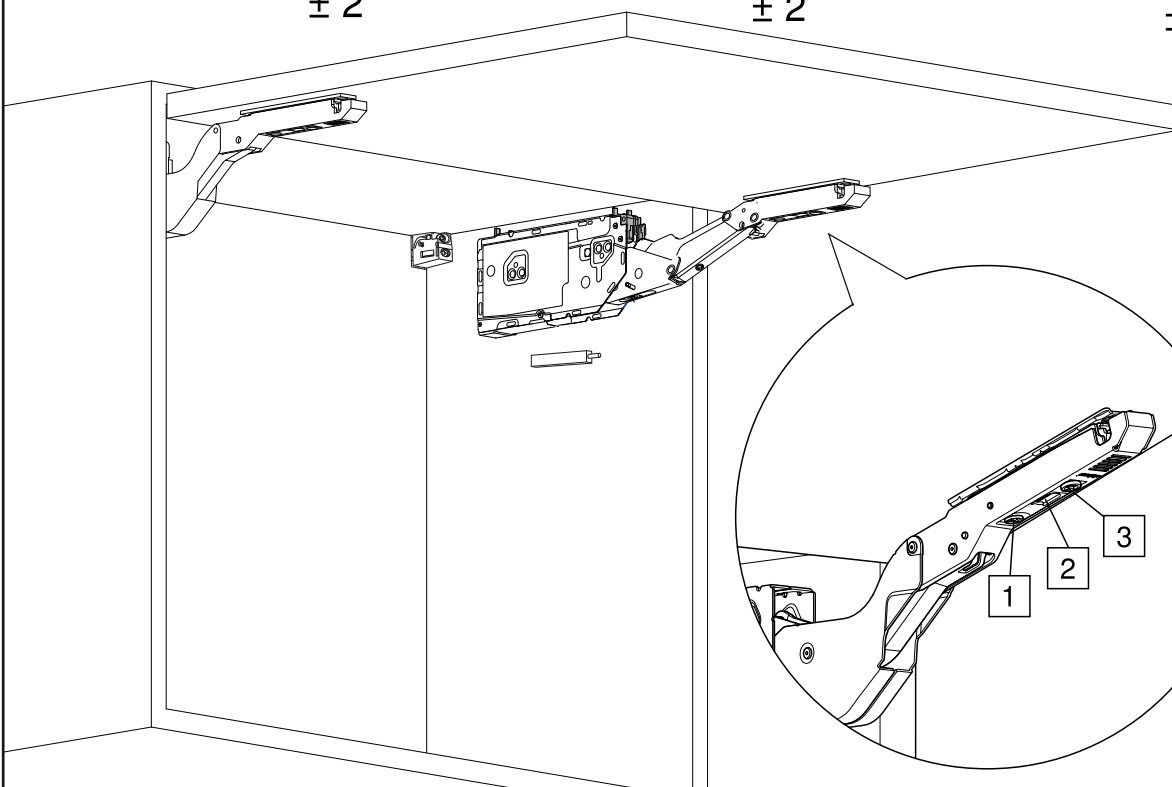

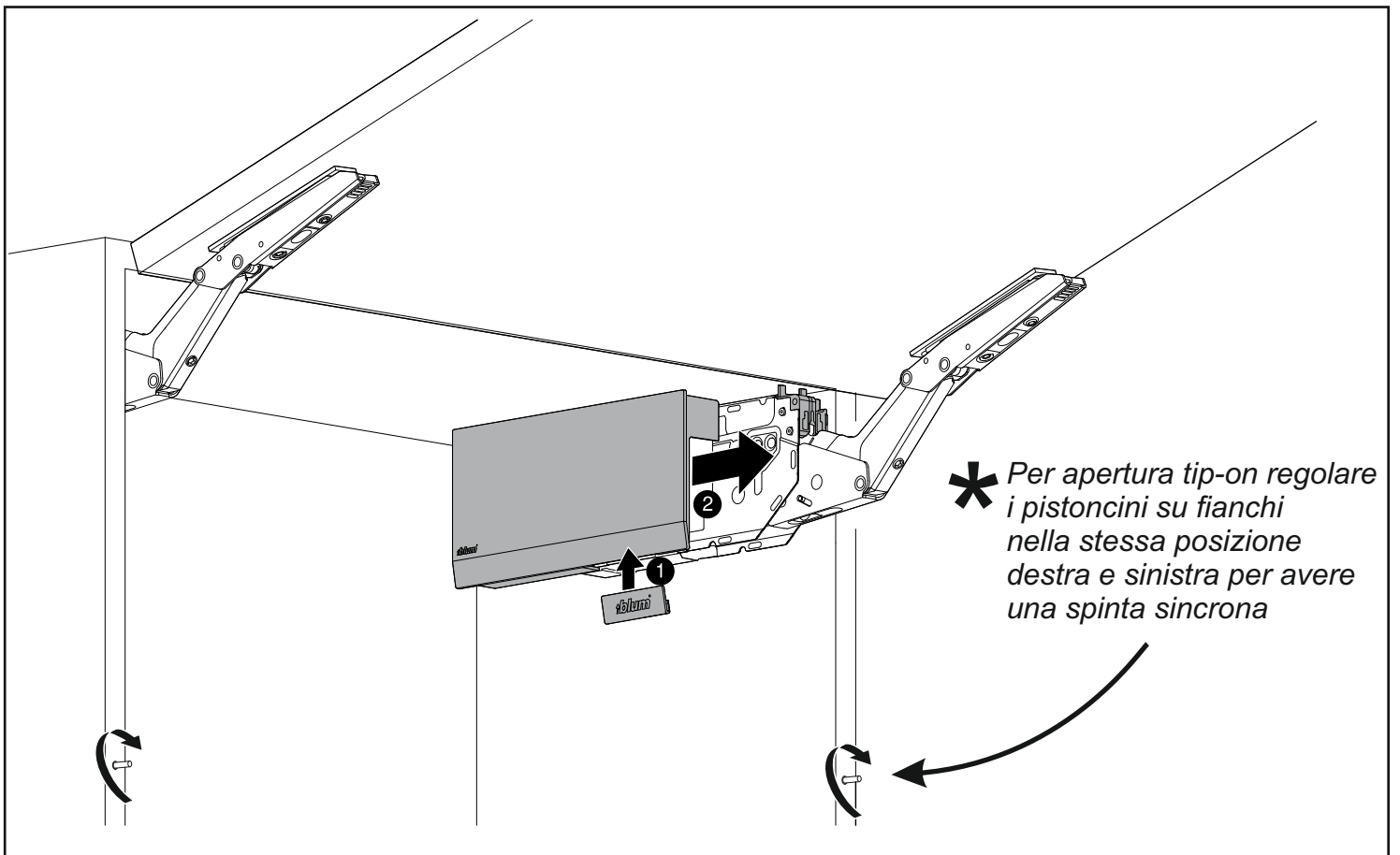

***** Per pensile con $L > 900\text{mm}$ inserire la barra di supporto sul retro dello scocca e la barra antiflessione per il ripiano prima di assemblare le ante

