

se top
sp.12/20mm

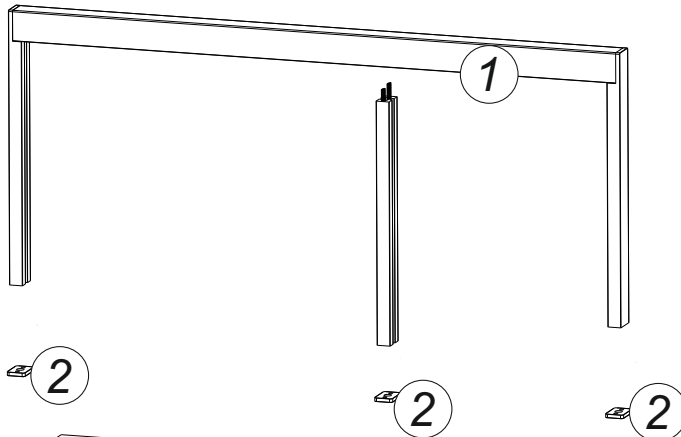

1 **TELAIO METALLO**

2 **PIASTRINA**

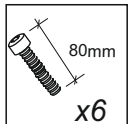

se top
sp.30/40/50mm

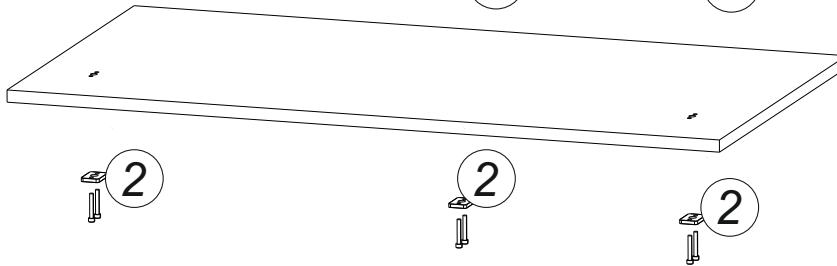

ASSEMBLAGGIO



Usare viti M6x40 se top sp.12/20mm
Usare viti M6x80 se top sp.30/40/50mm

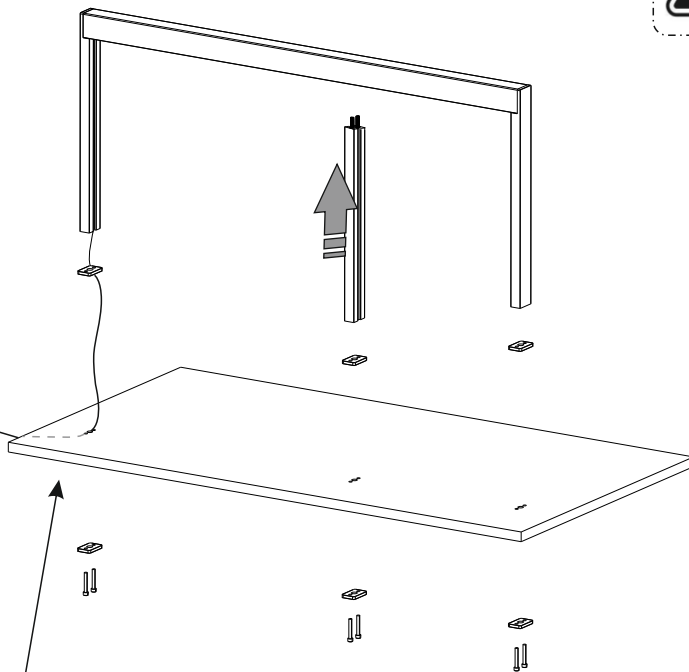

Infilare il cavo led nel foro centrale
prima di fissare il bridge con le viti

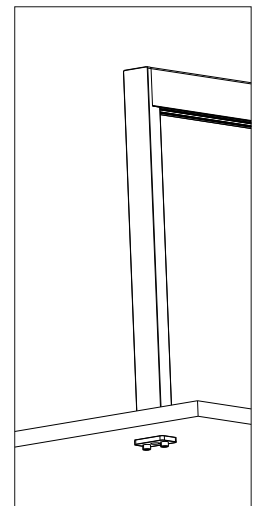
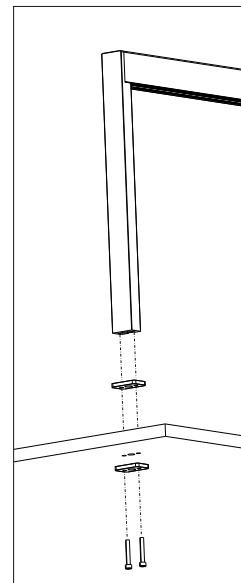

**NON USARE
AVVITATORE**

Un serraggio
eccessivo
potrebbe causare
la rottura del top

ASSEMBLAGGIO BRIDGE CON VETRO

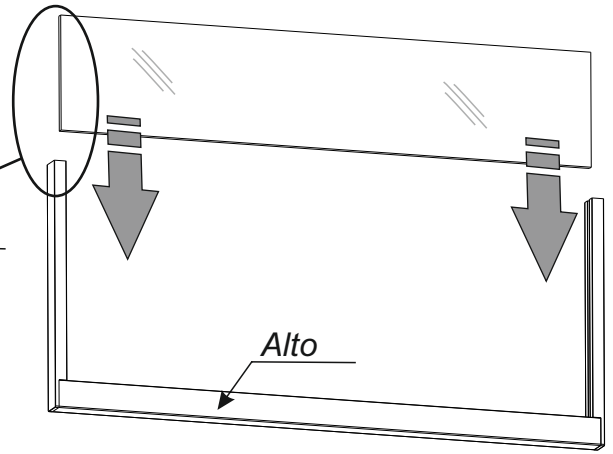
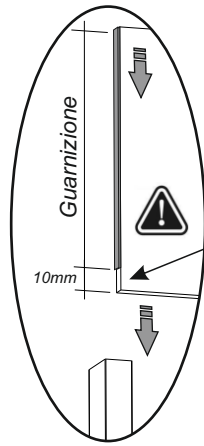
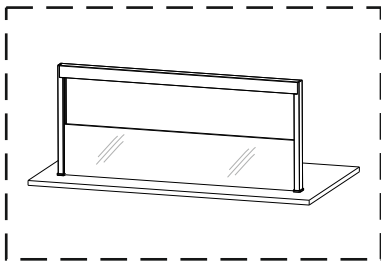

Posizionare lo scanco per il vetro dal lato interno del Bridge

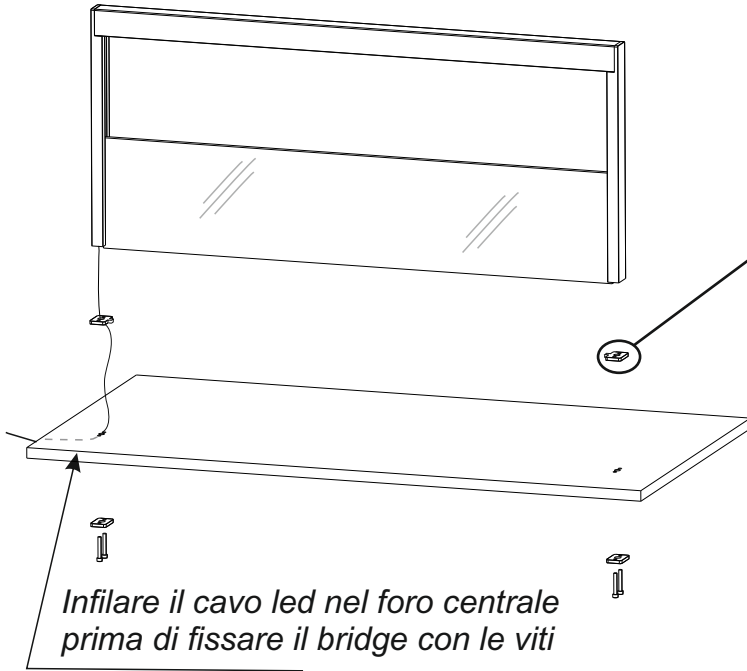
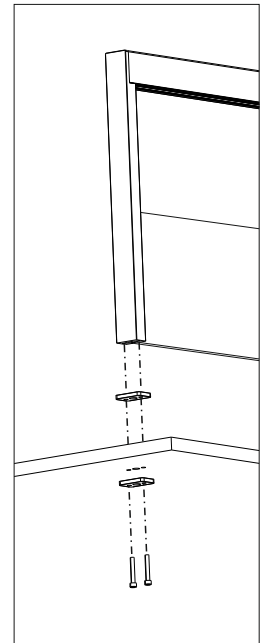
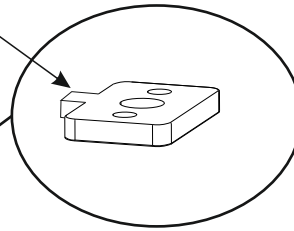

Infilare il cavo led nel foro centrale prima di fissare il bridge con le viti



Un serraggio eccessivo potrebbe causare la rottura del top



NON USARE AVVITATORE



Usare viti M6x40 se top sp. 12/20mm
Usare viti M6x80 se top sp. 30/40/50mm

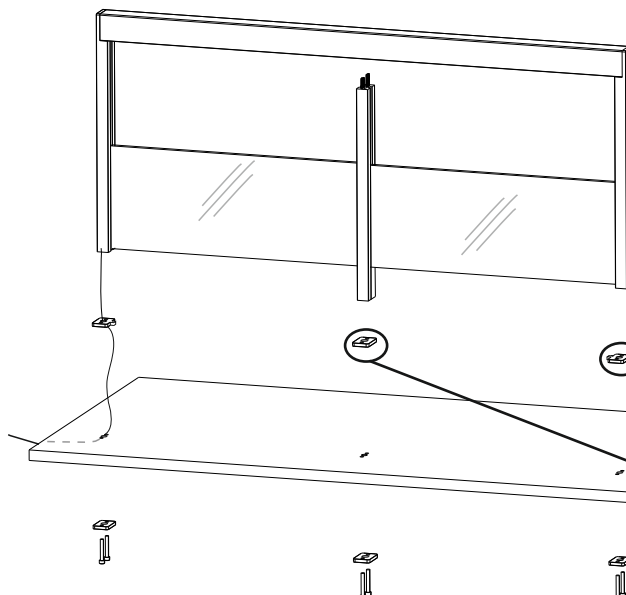
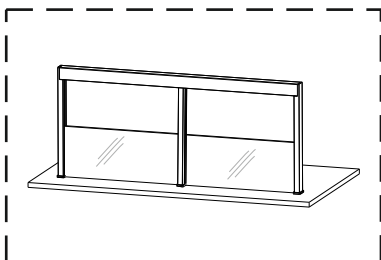

Posizionare lo scanco per il vetro dal lato interno del Bridge

